

# 7<sup>th</sup> International Abilitympics

## Vocational Skills Contest

### V11. Dress Making - Basic Course

#### 1. Task

Fabricate an apron in the design shown below using the pre-cut material, which will be provided.

#### 2. Allocated time

4 hours

#### 3. Instructions

- Adjustment of the sewing machine should be done by each contestant.
- The materials will be replaced only when there are flaws.
- Contestants are not allowed to lend or borrow tools during the contest.

#### 4. Specifications

- Shoulder strap: Completed width is 2cm. Use the sewing machine to make an edge-stitched seam.
- Waist strap: Completed width is 4 cm. Use the sewing machine to make an edge-stitched seam.
- Pocket
  - Top edge: Double-fold the cloth with margins of 1 cm and 2 cm, and seam them.
  - Sewing of pocket: Refer to Fig. 3 (How to Sew the Pocket). Double-stitch it using an edge-stitched seam and the width the presser foot, 0.6 cm.
- Inner facing: Double-fold the bottom of the facing with margins of 0.5 cm and 1 cm, and seam them.
- Sewing of shoulder strap: It must be interposed in the facing and bodice (the location to be marked on the fabric).
- Armhole curve: Fold a margin of 1 cm; the stitch width at the armholes up to the chest is 0.6 cm (the width of the presser foot).
- Side and hem: Double-fold the edge with margins of 1 cm and 1.5 cm, and seam them. The order of stitching shall be: stitch the hem, and then seam the side after interposing the waist strap in it.

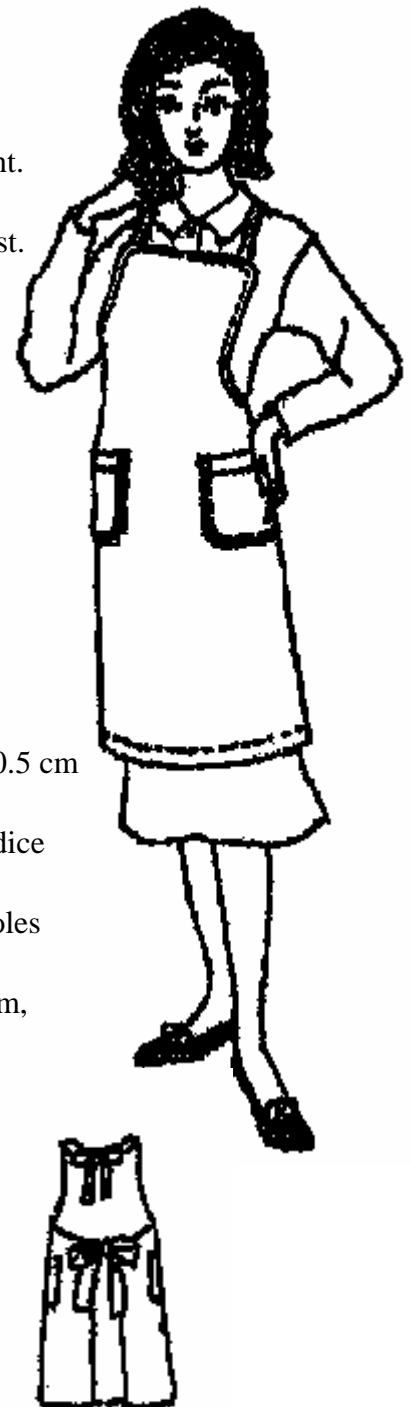

### 5. Items to be prepared on site

	Item	Standard	Qty	Remarks
Equipment	Working table	1800 x 900 x 700 (mm) or similar size	1	One per contestant
	Sewing machine	Automatic thread trimmer for industrial use	1	
	Bobbin case		1	
	Bobbin		2	
	Sewing machine needle		2	For industrial use
Tools	Iron	Household steam iron	1	
	Sheet		1	
Materials	Outer material	Cotton medium-thick cloth	For one apron	Already cut out Armholes attached with bias tape Already locked
	Machine-sewing thread	Synthetic thread #60	1	
	Paper pattern for pockets	Thick paper	1	

### 6. Items to be brought by each contestant

Item	Standard	Qty	Remarks
Set of sewing tools	At each contestant's discretion		Fabric shears, small scissors, prick punch, ruler, chalk, stitch ruler, hand sewing needle, etc.

(Note)

Contestants who wish to bring their own tools including those listed in Sections 5 and 6 above are requested to prepare a list of such tools and present it to the organizer for approval in advance. The organizer reserves the right not to allow the use of any tools that are considered to give the contestant an unfair advantage.

## 7. Evaluation criteria

The skills of each contestant will be assessed based on the final work produced.

Items to be evaluated	Maximum marks allotted
Sewing of pocket	15
Making of waist and shoulder straps	25
Seaming of side and hem	16
Facing and armholes	32
Overall appearance	12
Total marks	100

**Fig. 1**

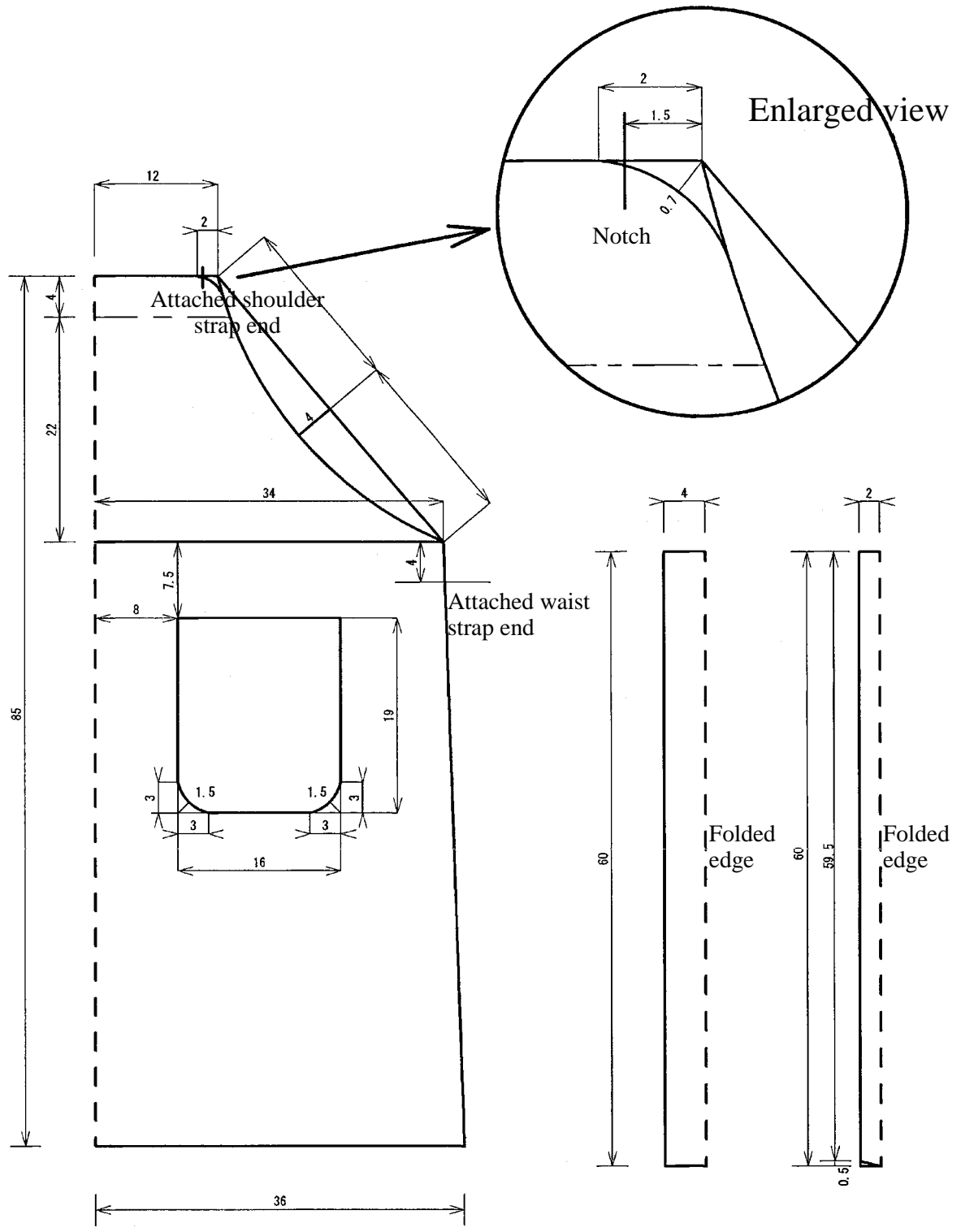

**Fig. 2**

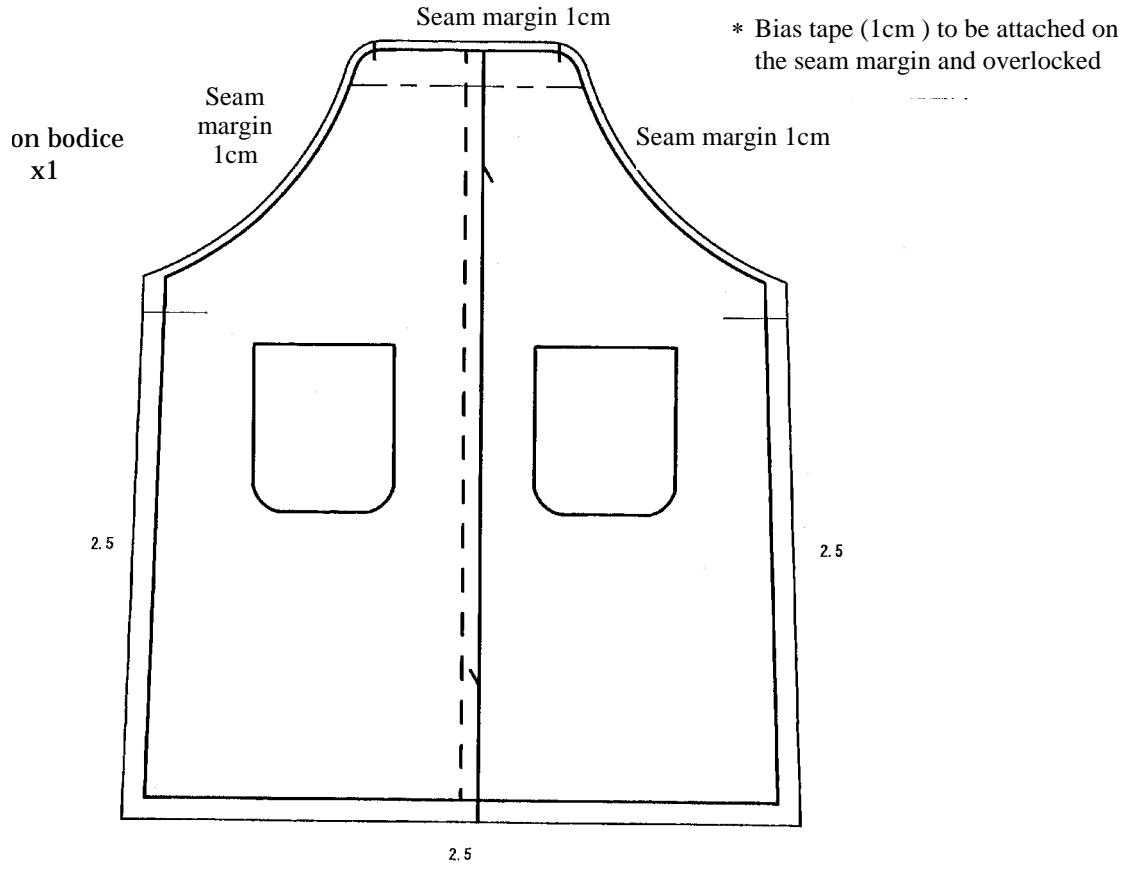

Apron pocket  
x 2

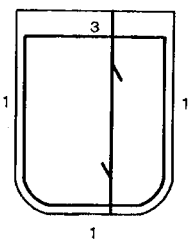

Apron shoulder strap  
x 2

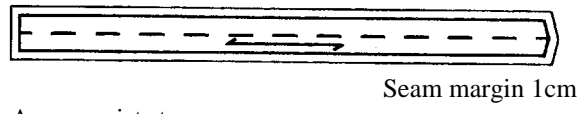

Apron waist strap  
x 2

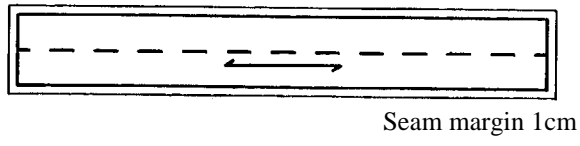

Apron facing  
x 1

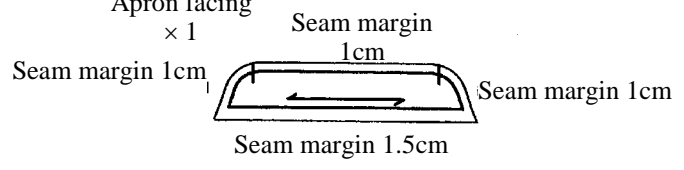

### Fig. 3 How to sew the pocket

Width of presser foot (0.6)

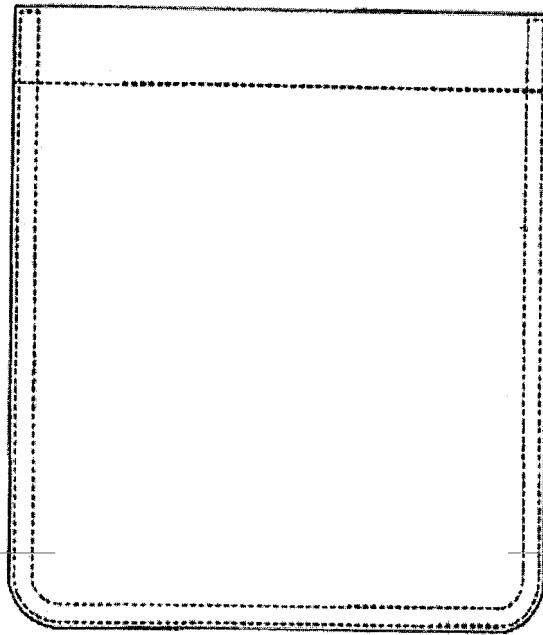

Start of stitch

End of stitch

(Superimposed seam)

2cm

Edge-stitched seam